

Data Sheet: PCB64PD

64 point Controller Board

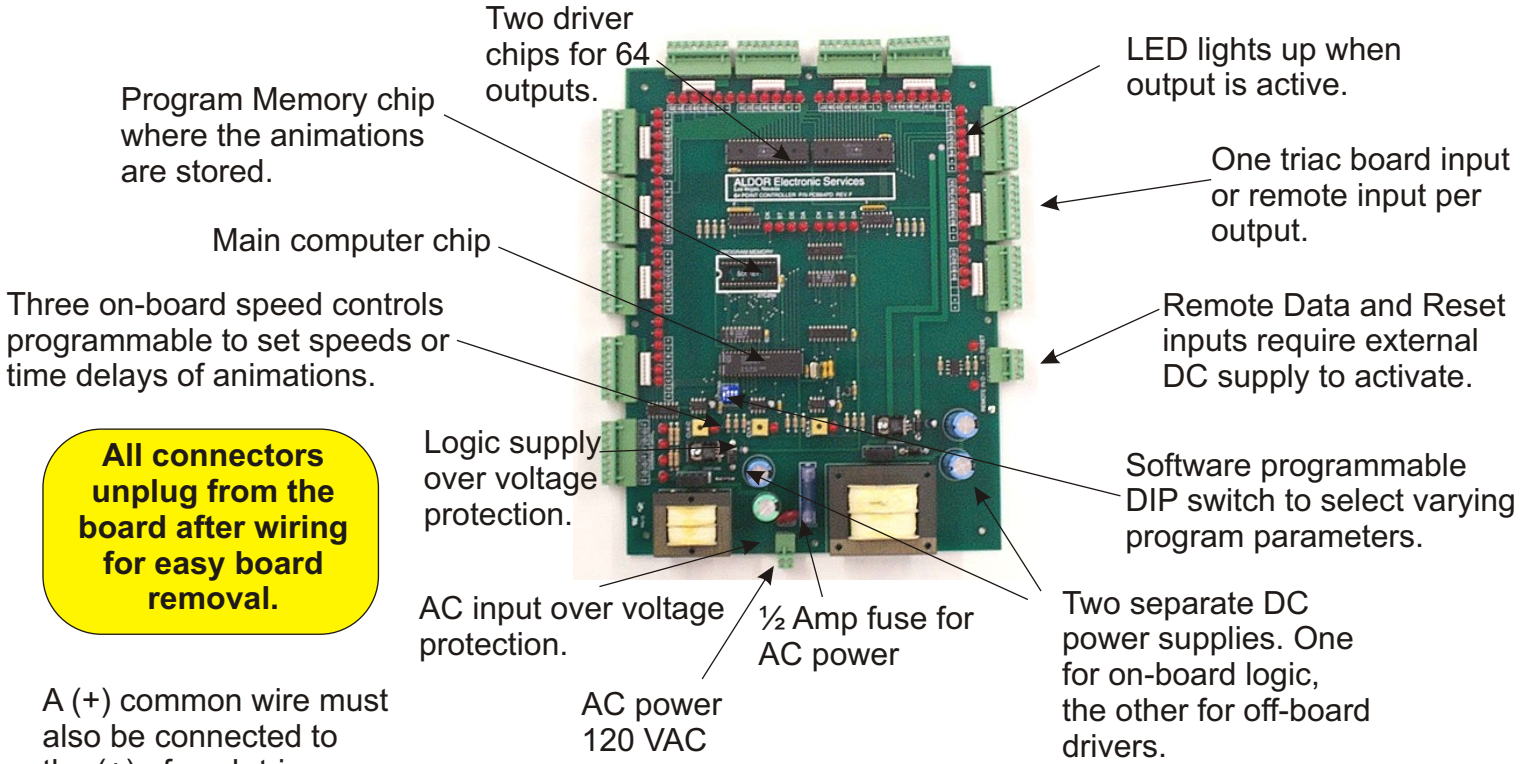

2961 Industrial Rd., #212, Las Vegas, Nevada 89109
Ph: 702-631-3400 / cell: 702-271-1859
Email: aldor@coam.net / Web: www.aldor.net



TYPICAL WIRING CONCEPT

