

Data Sheet: PCB10T4

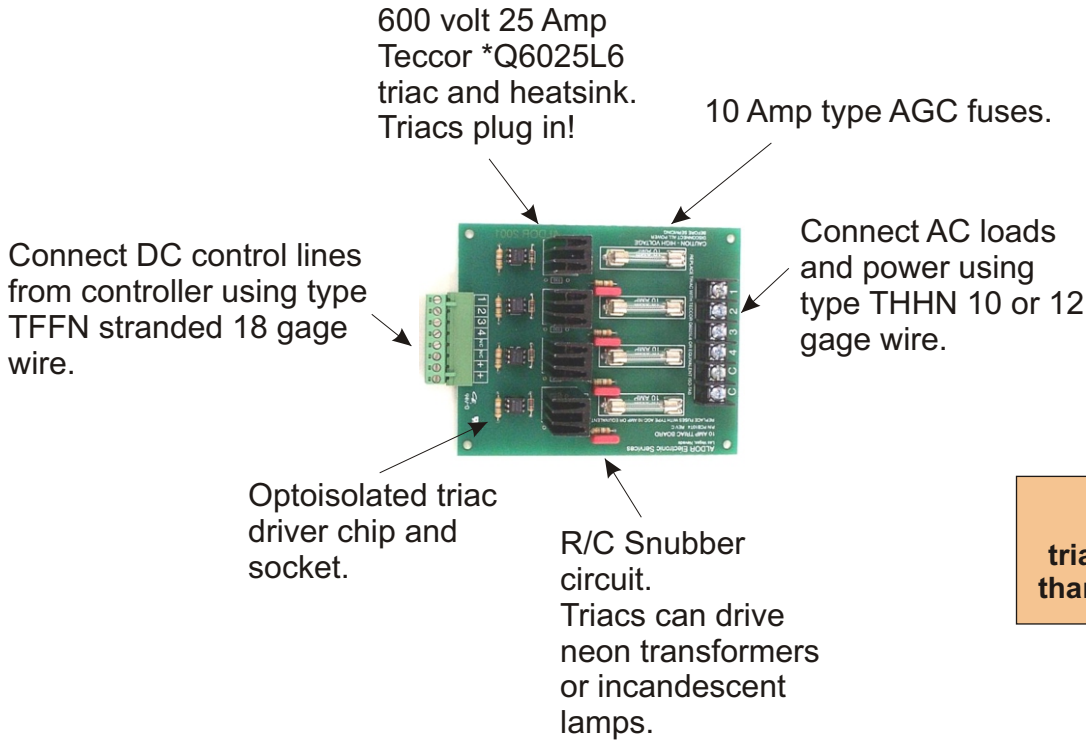

10 Amp 4 Point Triac Board

2961 Industrial Rd., #212, Las Vegas, Nevada 89109
Ph: 702-631-3400 / cell: 702-271-1859
Email: aldor@coam.net / Web: www.aldor.net



The AC load per triac should be no more than 6.5 Amps maximum.

TYPICAL WIRING CONCEPT

