

Data Sheet:  
PCB06PD



6 point Controller Board

2961 Industrial Rd., #212, Las Vegas, Nevada 89109  
Ph: 702-631-3400 / cell: 702-271-1859  
Email: aldor@coam.net / Web: www.aldor.net

All connectors unplug from the board after wiring for easy board removal.

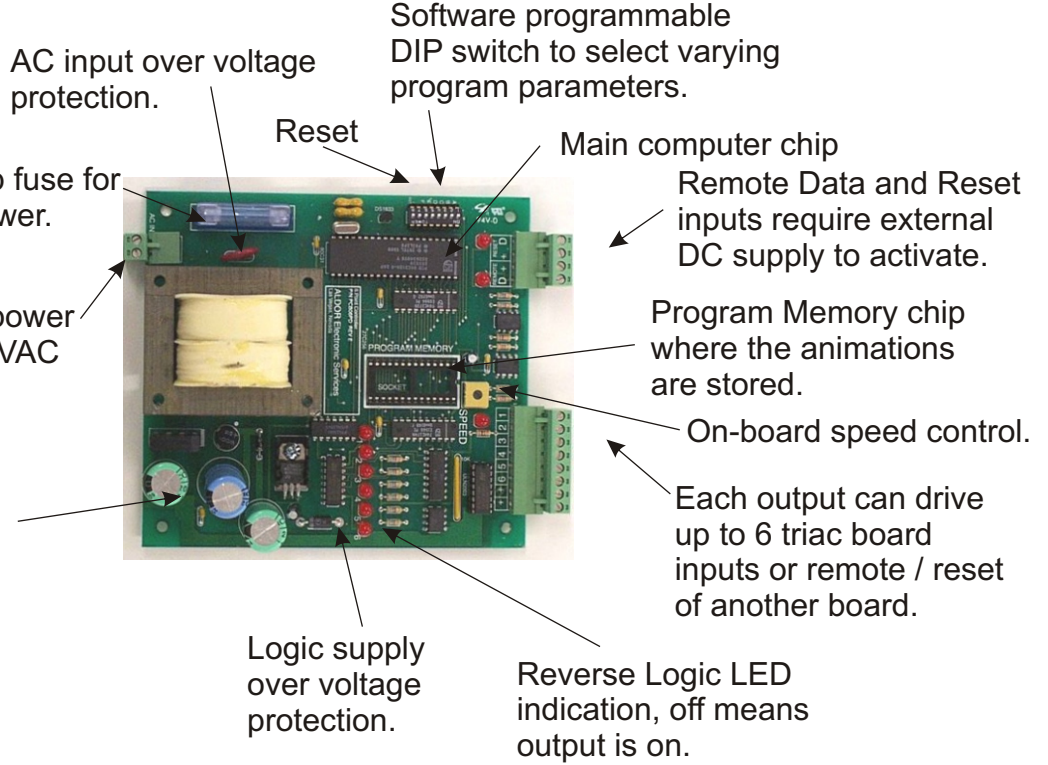

All controller boards should be powered from a "clean" AC line through one separate circuit breaker.

## TYPICAL WIRING CONCEPT

